



Metalworking Mist Collection Systems

 **Airflow**[®]
SYSTEMS INC.
Performance | Productivity | Payback

Market Driven Product Solutions

Airflow Systems, Inc.[®] manufactures a full line of mist collection and filtration systems for all types of metalworking applications, including wet grinding, EDM, and CNC turning and milling. Extensive field experience and technological expertise are the basis for product designs that help to satisfy worker, facility, regulatory, and budgetary demands in each type of metalworking application.



Oil Mist Collection: Pushing the Limits

In 1999, the Metalworking Fluids Standards Advisory Committee (MWFSAC) recommended to OSHA that the total exposure level limit of oil mist be lowered from 5.0 mg/m³ to 0.5 mg/m³, a 90 percent decrease in allowable levels from the previous limit. The recommendation was based on a NIOSH study indicating a new standard was necessary to protect workers from skin and respiratory disorders, as well as the increased risk of numerous forms of cancer. The new standard challenges the metalworking industry to consider significant process and design changes to achieve these lower emission levels.

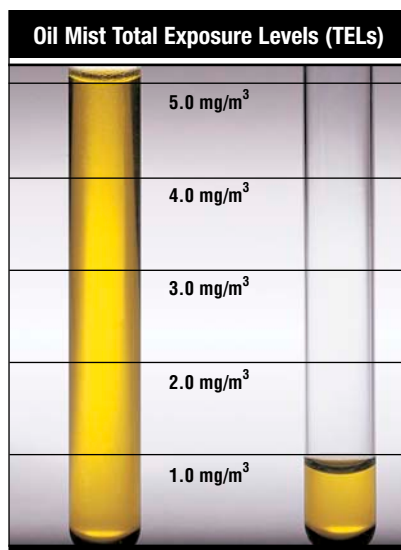

A NIOSH-directed study recommends that the total exposure level to oil mist be reduced to 0.5 mg/m³, a 90 percent decrease from the previous standard, a level that many mist filtration systems cannot effectively maintain. For more information, visit: www.osha.gov

Now What? How to Keep the Good News Good

Improving the work environment is always good news, but not always easy. A new technology from Airflow Systems, the Mist-Plus[™] Contaminant Management System, makes it easy to achieve the lower emission levels necessary to meet new



standards and improve worker health. Designed specifically for the metalworking industry, the Mist-Plus[™] Contaminant Management System uses a proprietary barrier-type mist collection and filtration system. While conventional oil mist collection systems are subject to dust and dirt loading, the Mist-Plus[™] Contaminant Management System allows for 24 hour, 7 day per week operation with long filter life and minimum downtime. Primary Mist-Plus[™] filters may be washed and re-used reducing filter replacement expense.

Eliminate the Options: The Choice Is Clear

The Mist-Plus[™] Contaminant Management System provides high efficiency — up to 99.97% with an optional HEPA filter — over the full life of the filter. This performance was confirmed in specific mist collection tests using the oil mist test procedures developed by the University of North Carolina, and conducted in accordance with methods approved by Ford Motor Company and the United Auto Workers. The Mist-Plus[™] filter media is less susceptible to dust and dirt loading, and the increased drainage provided by the Mist-Plus[™] Contaminant Management System's barrier-type design extends filter life and decreases maintenance requirements.

Airflow Mist-Plus™: Oil Mist Contaminant Management

Leaving Dust Filters in the Dust

Most pleated and pocket filter-type mist collectors are design adaptations of dry dust collection systems and are inadequate for many types of oil mist collection — particularly respirable droplets of 3.0 microns and smaller. Dust filter-type designs typically load quickly with oil mist and provide little or no drainage. As a result, filters must be changed often to maintain collection efficiency and acceptable air flow levels. The Mist-Plus™ Contaminant Management System, designed specifically for oil mist applications, consists of multiple layers of glass media contained in specially designed frames to collect, remove, and drain collected fluids. Dust and dirt loading is significantly decreased and the superior drainage efficiency extends filter life and decreases maintenance requirements.

Washable Filter Design

Improves overall system operating costs. Filter replacement frequency and costs are reduced; maintenance cycles are extended.

Clean Air Release

Open filter frame design allows unrestricted release of clean air back into the work environment for maximum operating efficiency.

First Loading Layer

The First Loading Layer collects larger dry particles, removing them from the air flow path while maintaining the integrity of the high-efficiency Fiber Barrier Layer.

Fiber Barrier Layer

A high-efficiency (95% + efficient on 1 to 4 micron mist droplets) glass fiber barrier collects the fine oil mist particles, agglomerating the mist to better facilitate re-liquification and drainage.

Contaminant Management Layer

This proprietary layer collects agglomerated liquid and drains it from the Fiber Barrier to the sump, extending filter life. The Fiber Barrier, together with the Contaminant Management Layer, eliminate the need for less efficient collection pleats and the air-to-cloth ratio concerns common with pleated dust-style collection cartridges.

Gravitational Filter Design

These washable, V-shape or circular design filters use gravitational pull to aid in the drainage of collected mist, reducing filter replacement cost and frequency. (Circular filter design used in MP4).

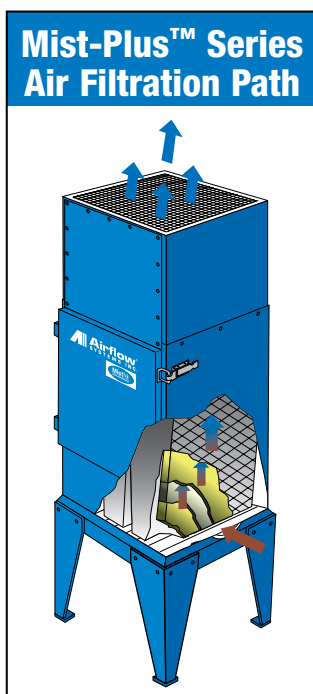

Air flow passes through four filtration stages, maximizing filtration efficiency without compromising motor/blower operating efficiency.

- 1 Aluminum Mesh Pre-filter
- 2 First Loading Layer
- 3 Fiber Barrier Layer
- 4 Contaminant Management Layer

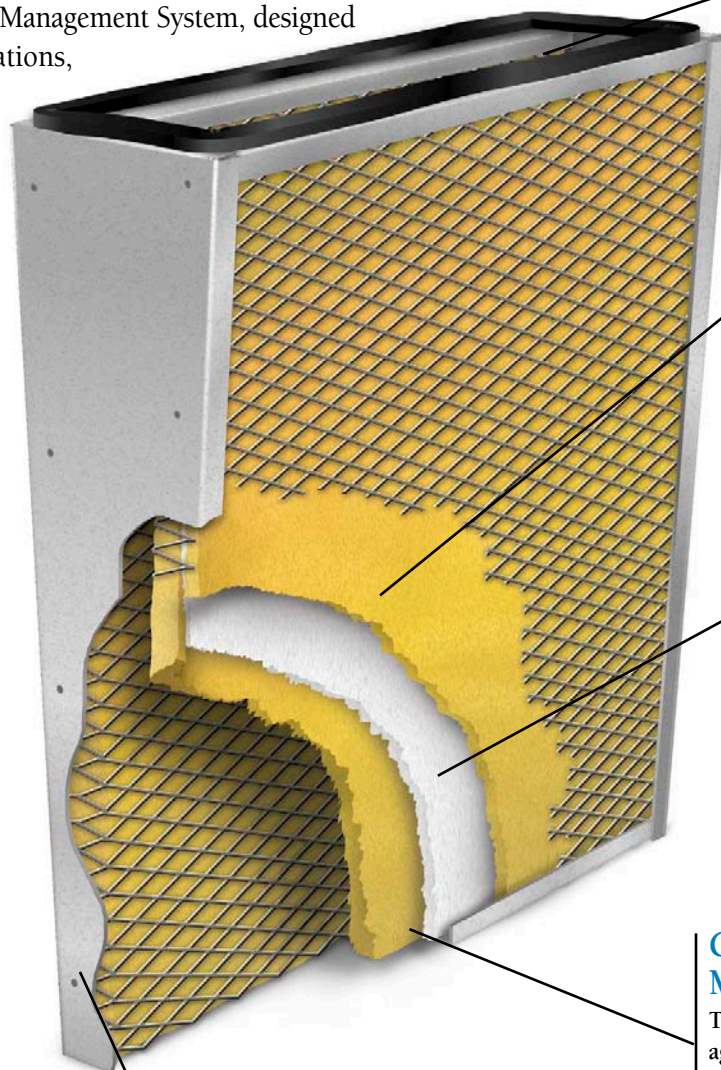

Mist-Pak™ Series Models MP4 & MP14

MP4 Application Overview

The Model MP4 is designed for single-unit metalworking applications. It produces from 400 to 600 CFM with 95% filtration efficiency. The Model MP4 features a bottom inlet for simple, machine-top mounting or above unit hanging. Its small, 1.8 square foot cabinet footprint requires minimal floor space and eases installation.



Mist-Pak™ Model MP4

Air Flow (CFM)	Efficiency	Inlet	Weight (lbs.)	Sound Level (dBA)	Blower Package(s)	Filter Modules
600 dry/400 wet	95%*	6" bottom only	105	73	0.75 HP single or three phase	1" aluminum mesh pre-filter; (1) Mist-Plus™ primary filter (Circular design)

*Efficiency based on UAW-approved UNC oil mist test method.

MP14 Application Overview

The Model MP14 is designed for medium-duty metalworking applications. It produces from 1000 to 1400 CFM with 95% filtration efficiency for single or multiple machine tool collection systems. The MP14 features an inlet at the bottom to allow for shorter cabinet design, and can be mounted on top of a machine tool. Its small, 2.4 square foot cabinet footprint requires minimal floor space and eases installation.



Mist-Pak™ Model MP14

Air Flow (CFM)	Efficiency	Inlet	Weight (lbs.)	Sound Level (dBA)	Blower Package(s)	Filter Modules
1,000 dry, 1,400 (optional)	95%*	10" bottom only inlet plenum & stand available	150	75	1.5 HP, or 1.5 High Flow (optional) single or three phase	2" aluminum mesh pre-filter; (3) Mist-Plus™ primary filters (V-shape design)

*Efficiency based on UAW-approved UNC oil mist test method.

Mist-Pak™ Series Models MP30 & MP60



MP30 Application Overview

The Model MP30 is designed for use in medium- to heavy-duty metalworking applications. It produces from 2400 to 3000 CFM with 95% filtration efficiency. The MP30 features multiple inlet location options to easily facilitate collection from multiple machine tools. Its small, 4 square foot cabinet footprint requires minimal floor space. Units can be hung or floor mounted.



Mist-Pak™ Model MP30

Air Flow (CFM)	Efficiency	Inlet	Weight (lbs.)	Sound Level (dBA)	Blower Package(s)	Filter Modules
3,000, 2,400 (optional)	95%*	14" sides & back only; 12" front	350	78	5 HP, 3 HP (optional) three phase	2" aluminum mesh pre-filters; (4) Mist-Plus™ primary filters (V-shape design)

**Efficiency based on UAW-approved UNC oil mist test method.*



MP60 Application Overview

The Model MP60 is designed for use in heavy-duty metalworking applications. It produces 6000 CFM, with 95% filtration efficiency for single- or multiple-unit collection systems. The MP60 features a sloped drain pan for faster reclamation of captured oil mist, and a 24 inch stand for secure floor mounting.



Model MP30 Shown

Mist-Pak™ Model MP60

Air Flow (CFM)	Efficiency	Inlet	Weight (lbs.)	Sound Level (dBA)	Blower Package(s)	Filter Modules
6,000	95%*	20" sides & back, 18" front	771	79	10 HP three phase	(2) 2" aluminum mesh pre-filters; (8) Mist-Plus™ primary filters (V-shape design)

**Efficiency based on UAW-approved UNC oil mist test method.*

Mist-Pak™ Series Model MP120



MP120 Application Overview

The Model MP120 is designed for use in extremely heavy-duty, multiple machine tool metal-working applications. It produces 12,000 CFM, with 95% filtration efficiency. The MP120 features a sloped drain pan for faster reclamation of captured oil mist, and a 24 inch stand for floor mount installation.



Model MP30 Shown

Mist-Pak™ Model MP120

Air Flow (CFM)	Efficiency	Inlet	Weight (lbs.)	Sound Level (dBA)	Blower Package(s)	Filter Modules
12,000	95%*	28" side or, 20" back	1550	79	20 HP three phase	(4) 2" aluminum mesh pre-filters; (16) Mist-Plus™ primary filters (V-shape design)

*Efficiency based on UAW-approved UNC oil mist test method.

Mist-Pak™ Series Optional Equipment

Optional Equipment	Mist-Pak™ Series MP4	Mist-Pak™ Series MP14	Mist-Pak™ Series MP30	Mist-Pak™ Series MP60	Mist-Pak™ Series MP120
Pressure Gauge Kit Indicates when filters require cleaning	■	■	■	■	■
Pre-filters Polyester pads	■ 1"	■ 2"	■ 2"	■ 2"	■ 2"
After-filters 99.97% HEPA, 95% DOP & Odor Modules	■	■	■	■	■
Drain Loop Kit Simplifies oil collection/reclamation; provides drain line air seal	■	■	■	■	■
Floor Stand Stabilizes floor-mount units; eases maintenance	■ 5 & 24 inch	■ 8 & 24 inch	■ 24 inch	■ Standard 24 inch	■ Standard 24 inch
Adsorption Modules 12" V-bank refillable after-filters	■	■	■	■	■

Mist-Pak™ Pro Series

Pro 1 & Pro 2 Application Overview

Models Pro 1 and Pro 2 provide ultra-high efficiency filtration of oil, coolant, and other mists generated during metalworking applications. Pro 1 and Pro 2 models deliver 99.97% efficiency at 3.0 micron particle size. Cabinet seams are welded, not bolted; and filters are secured with the Ultra-Seal® filter mounting system to eliminate contaminant bypass and escape.



Model Pro 1 & Pro 2

Pro 1 & Pro 2

Air Flow (CFM)	Efficiency	Inlet	Weight (lbs.)	Sound Level (dBA)	Blower Package(s)	Filter Modules
Pro 1						
500	99.97% with HEPA after-filter	10" bottom	200	75	.75 HP	MistPlus® II ultra-high efficiency
Pro 2						
1300	99.97% with HEPA after-filter	10" side(s)	450	78	2.0 HP	MistPlus® II ultra-high efficiency

Pro 3 & Pro 4 Application Overview

Models Pro 3 and Pro 4 provide ultra-high efficiency filtration in applications requiring air flow levels up to 5,500 CFM. Airborne mists are removed from the work area at 99.97% efficiency at 3.0 micron particle size. Washable MistPlus® II filters reduce maintenance and extend filter life with a 2-year filter life guarantee.



Model Pro 3 & Pro 4

Pro 3 & Pro 4

Air Flow (CFM)	Efficiency	Inlet	Weight (lbs.)	Sound Level (dBA)	Blower Package(s)	Filter Modules
Pro 3						
2400	99.97% with HEPA after-filter	14" side(s)	900	78	3.0 HP	MistPlus® II ultra-high efficiency
Pro 4						
3500 (5 HP) 5500 (10 HP)	99.97% with HEPA after-filter	20" side(s)	1,760	79	5.0 HP (10.0 optional)	MistPlus® II ultra-high efficiency

E-Z Arm® Extractor Arms

Positionable, high-efficiency units provide source-point collection in a variety of applications. Model choices include units for close-in work and multiple-arm collection, as well as stainless steel and food grade units. Arms are available in a range of lengths and air flow capacities.



Portable Collectors

Easily wheeled directly to a pollutant source, these complete, self-contained, low profile units feature an E-Z Arm® High Flow Extractor Arm, blower, and filter cartridge. A low profile cabinet allows for safe maneuverability and arm positioning.



Downdraft Benches

Source collection efficiency for applications that require larger, open collection areas and work surfaces. Particulate collection is incorporated with a work surface in a design that draws contaminants away from worker breathing zones. Available in stationary or portable designs, and in units designed exclusively for aluminum finishing and processing.



High Vacuum Units

Single units provide power for simultaneous, high-powered source collection from multiple work stations. Able to work with long cable systems. Non-electrostatic operation for high reliability, low maintenance.



Dust Collectors

Self-contained units collect and filter shop dust. Offered in a variety of designs that minimize ductwork and reduce installation costs. Available with casters for portability, and with floor stand/hopper to funnel dust away from filters and extend maintenance cycles.



Airflow[®]
SYSTEMS INC.

Performance | Productivity | Payback

11221 Pagemill Road • Dallas, TX 75243-8306 USA
Phone: 214-503-8008 • Fax: 214-503-9596

1-800-818-6185