

Tri-Kleen™ 500UV

Technical Information

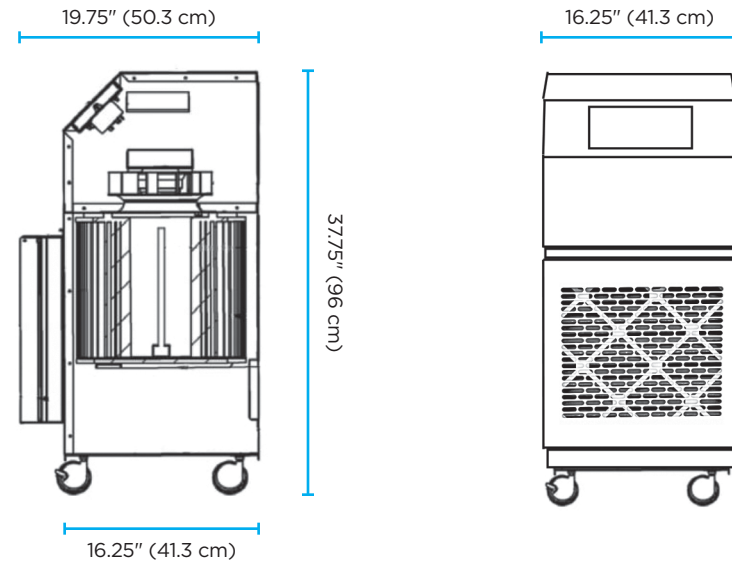

Features	Specifications
Net Weight With Filters	52 lbs (23.6 kg)
Shipping Weight	70 lbs (31.8 kg)
Unit Dimensions	W 16.25" x D 19.75" x H 37.75" (W 41.3 cm x D 50.3 cm x H 96 cm)
Shipping Carton Dimensions	W 20" x D 24" x H 44" (W 50.8 cm x D 61.0 cm x H 109 cm)
Power Supply Required	120 volts AC, 60 Hz, 15 amp circuit
Max. Current Draw	2.5 amps
Automatic Restart	Yes - the unit will automatically restart after temporary power interruption
Cabinet Material	0.050" (1.3 mm) thick steel painted white
Control Panel	LCD touch screen controls
Circuit Breaker	5-amp integrated circuit breaker
Filter Loading Indicator	Filter loading visual alarm on LCD touch screen with audible alarm (audible alarm can be (enabled/disabled)
Air Flow Ratings	3 speed settings produce an air flow range between 90 CFM to 500 CFM (150 m3/h - 850 m3/h)
Power Cord	10' (3 m) long, 14/3 AWG SJT hardwired power cord
Sound Level	52 dBA - 59 dBA
Pre-Filter	Standard pre-filter: 2" (5 cm) deep pleated MERV8 pre-filter
Hepa Filter	Cylindrical 99.97% efficient against 0.3 Qm particles at max. air flow, with UV lamp integrated into the filter
Exhaust Outlet	One exhaust collar located on top of unit. Exhaust collar dimensions: 12" x 8" (30.5 cm x 20.3 cm) Optional 8" nominal diameter (20.3 cm) exhaust collar included for connecting round ducting

Tri-Kleen™
500UV

Portable Air
Filtration Unit



All Your Air Cleaning And Air Purification Solutions

www.acs-cal.com

Tri-Kleen™ 500UV Portable Air Filtration Unit

THREE STAGES OF FILTRATION

The first stage panel filter is activated charcoal. This filter will remove odors/VOCs and will neutralize some virus particles. The second stage HEPA filter provides the most effective mechanical filtration available for viral aerosols. The third stage germicidal UV-C light is known for quickly neutralizing pathogens such as bacteria and viruses. An optional fourth stage hydroxyl generator offers an unparalleled level of protection without increasing the footprint.

The light weight Tri-Kleen™ can be used to circulate the air or create negative pressure in a space. Smooth rolling swivel casters (with front brakes) make it easy to move the device to a different location. Three speed settings (90 CFM - 500 CFM) allow this air machine to work in most applications.

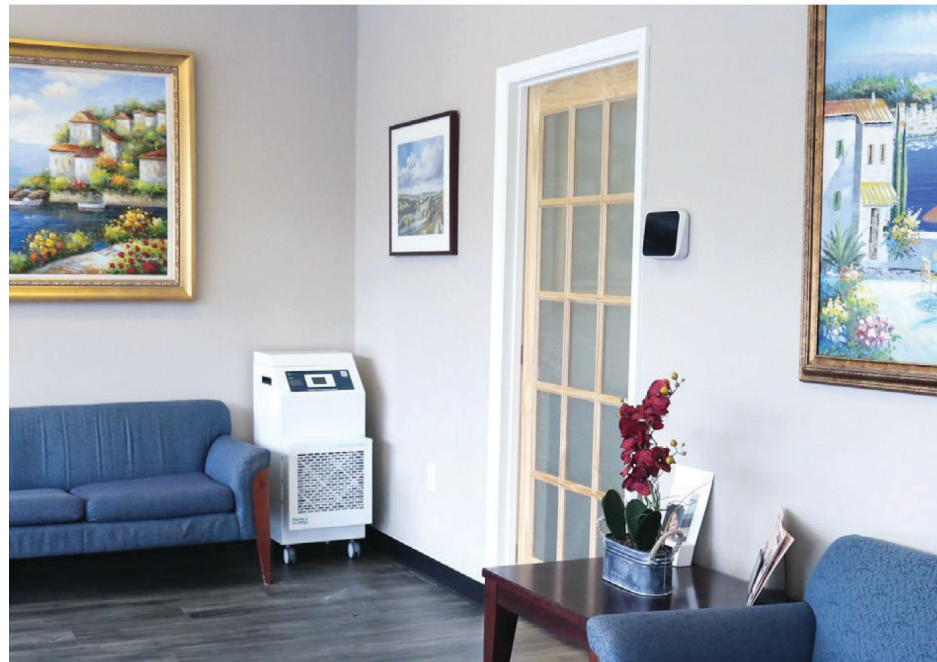

ADDITIONAL EQUIPMENT AVAILABLE

- HVAC Air Purification Systems
- Production/Warehouse Ambient Air Cleaners
- Dust Collectors
- Mist Collectors
- Wet Dust Collectors
- Dust Booths (environmental control)
- Downdraft Tables



3633 Pomona Boulevard
Pomona, CA 91768
info@acs-cal.com

909.620.7114

Tri-Kleen™ 500UV Technical Information

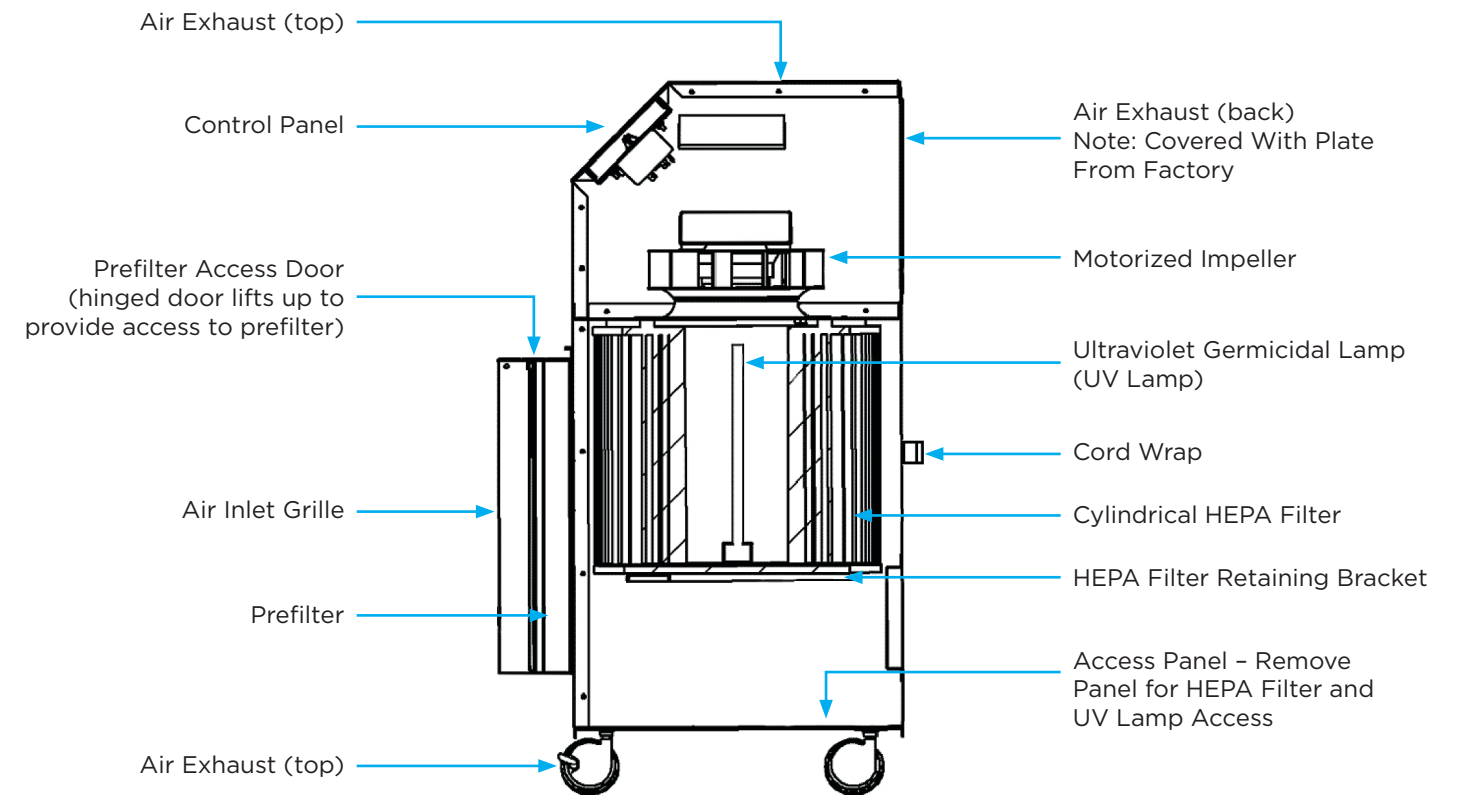

TRI-KLEEN™ 500UV FEATURES

Tri-Kleen™ 500UV has an optional exhaust collar that will allow for a flex duct to be attached and allow for the air to be exhausted to create a negative pressure in a space to allow for containment in a specific space.

OTHER FEATURES INCLUDE

- HEPA filter
- Three speed settings: from 90 CFM to 500 CFM
- Quiet (52 dBA - 59 dBA)
- Filter loading indicator with audible alarm
- Smooth-rolling swivel casters with two front brakes
- LCD touch screen with state-of-the-art touch pad controls

